

POOLS

GLAZED PORCELAIN & GLASS | POOL & CLADING TILES

PLAIN COLOUR TILES

ABSOLUTE

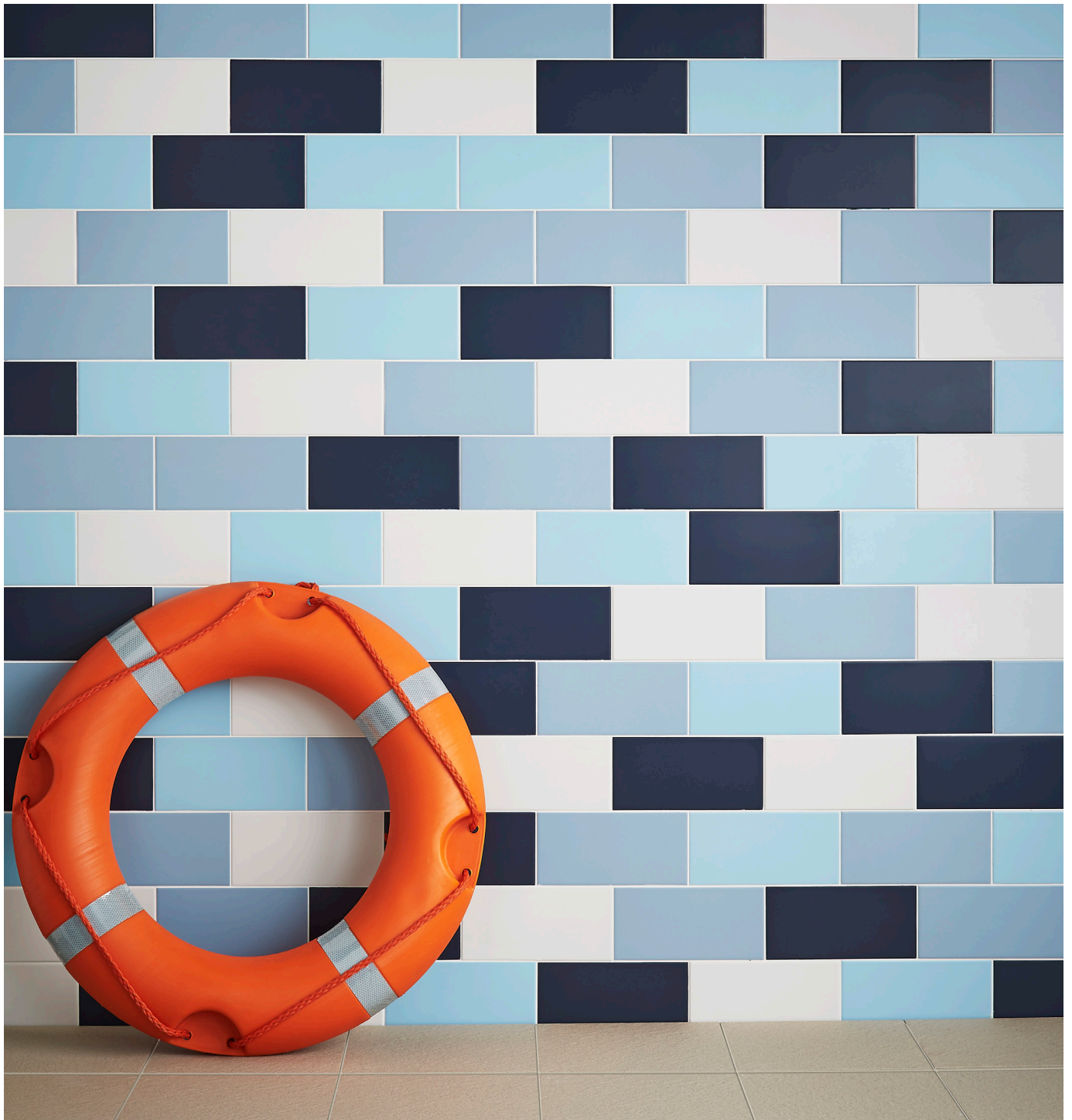

JOHNSON • TILES 

MADE IN THE UK SINCE 1901

POOLS

A versatile collection of swimming pool tank and cladding tiles, with co-ordinating swimming pool fittings. A range of colours are available, ranging from classic blue tones of Prussian Blue and Azure to bolder options of Red and Yellow, bring personality to your swimming pool design.

Front Cover Image: Azure Smooth (Ref.122 Tank Tiles) 250x125mm - AP841N,
Ultra Marine Smooth (Ref.122 Tank Tiles) 250x125mm - AP075N & Marine Smooth (Ref.122 Tank Tiles) 250x125mm - AP843N

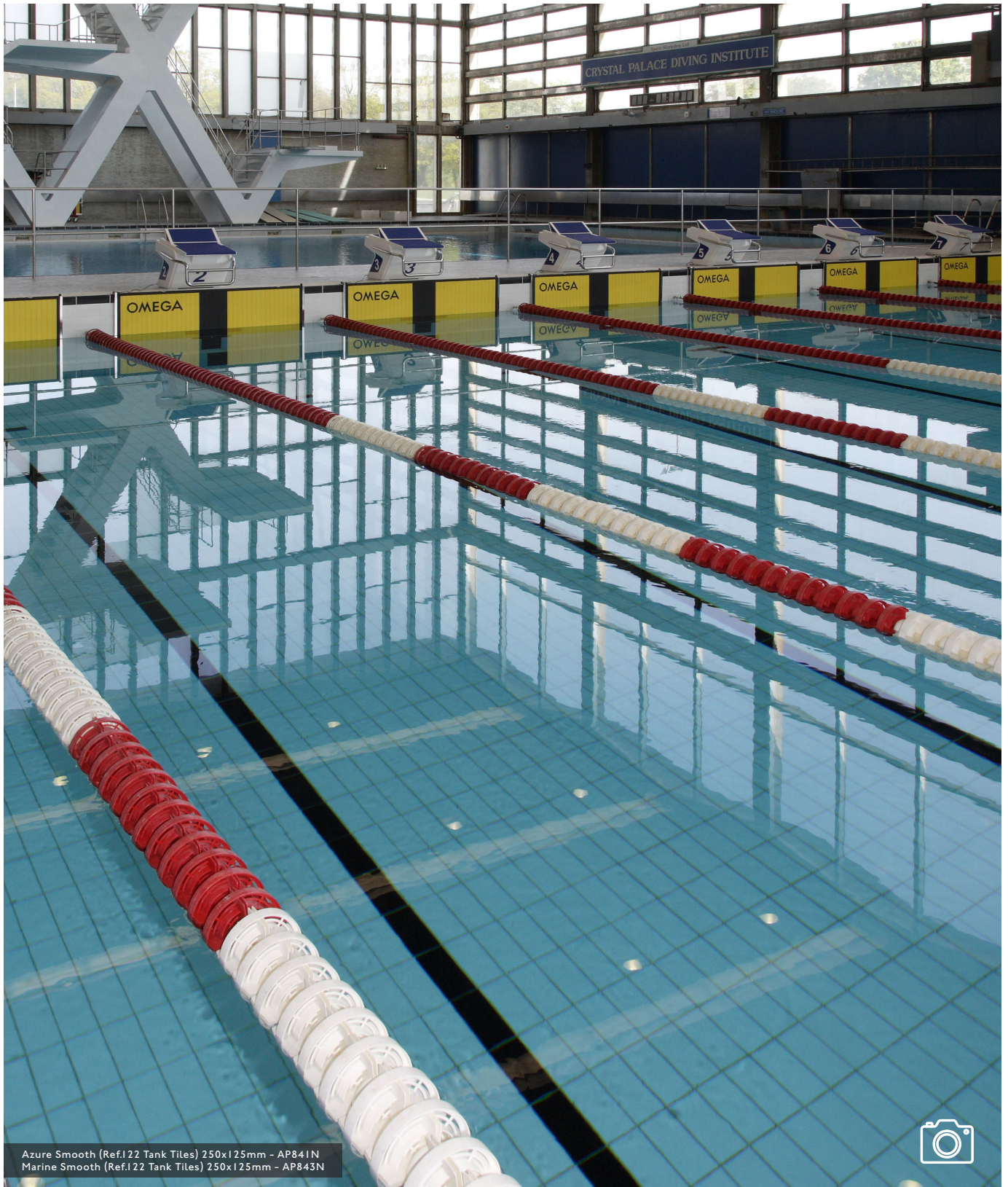

Azure Smooth (Ref.122 Tank Tiles) 250x125mm - AP841N
Marine Smooth (Ref.122 Tank Tiles) 250x125mm - AP843N



Colours & Product Codes

V1: Low Shade Variation

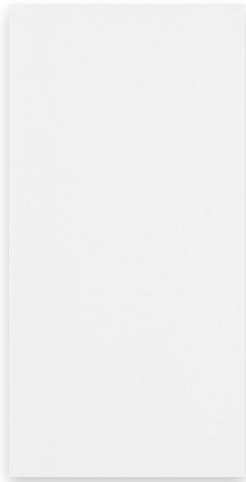

WHITE LRV: 74

(S) AP845N + (A) AP845A



AZURE LRV: 54

(S) AP841N + (A) AP841A

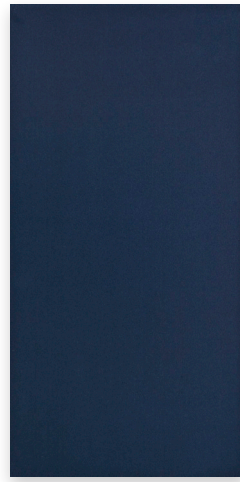

MARINE LRV: 10

(S) AP843N + (A) AP843A

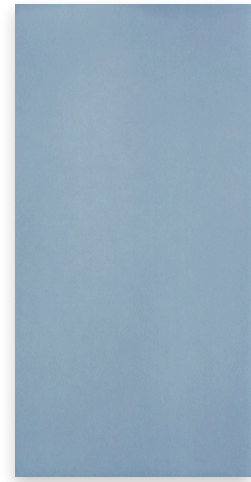

ULTRA MARINE LRV: 45

(S) AP075N

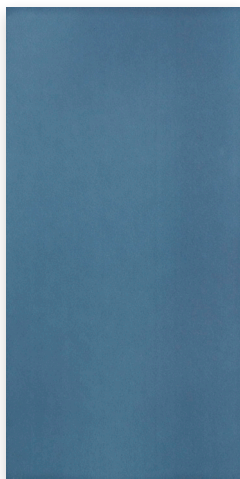

PRUSSIAN BLUE LRV: 24

(S) AP074N



OLIVE LRV: 30

(S) AP071N



CREAM LRV: 53

(S) AP072N

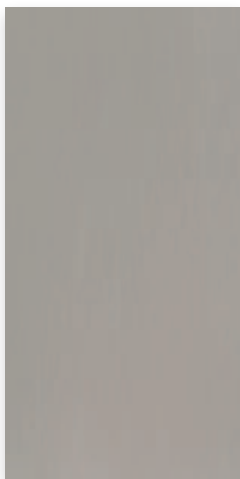

COFFEE LRV: 45

(S) AP073N

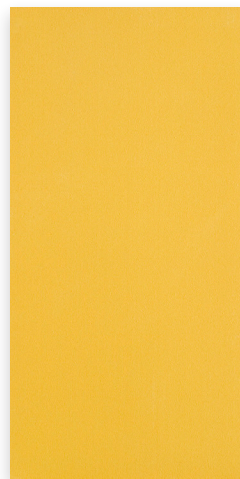

YELLOW LRV: 43

(S) AP630N

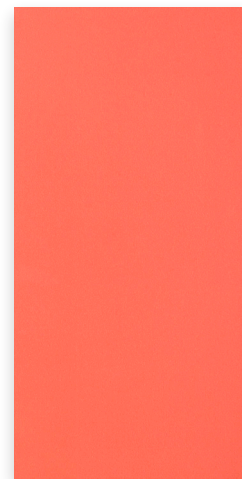

RED LRV: 21

(S) AP629N



GLACIER
RECTANGULAR MOSAIC

(S) AP851N + (A) AP851A LRV: 74

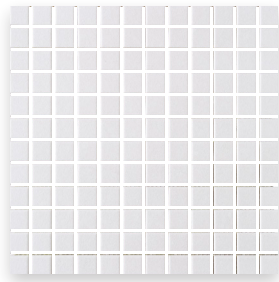

ICE
SQUARE MOSAIC

(S) AP901N + (A) AP901A LRV: 74

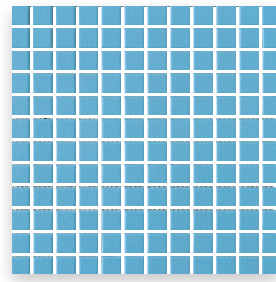

BLUE
SQUARE MOSAIC

(S) AP900N + (A) AP900A LRV: 54

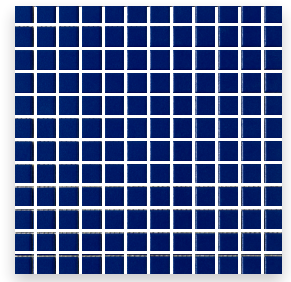

NAVY
SQUARE MOSAIC

(S) AP902N + (A) AP902A LRV: 10



Sizes, Finishes & Availability

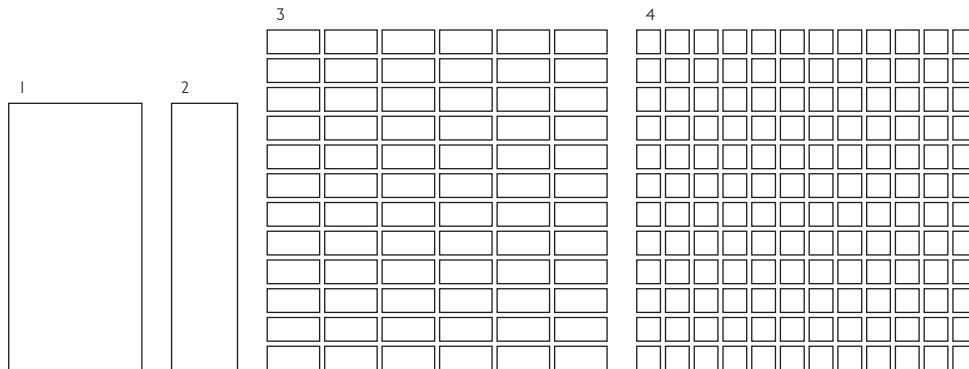

#	Size	Finish	Colour Availability	Thickness	Pieces/Box	Coverage/Box	Weight/Box
1	250x125mm Ref. 122 Tank Tile	(S) Smooth	All Colours Shown	8mm	42 Tiles	1.32 m ²	22.26 kg
		(A) Antislip	White, Azure & Marine Only	8mm	42 Tiles	1.32 m ²	22.26 kg
2	250x62mm Ref. 052 Tank Tile	(S) Smooth	All Colours Shown	8mm	30 Tiles	0.47 m ²	7.50 kg
3	320x320mm (50x20mm) Ref. 323 Rectangular Mosaic	(S) Smooth	Glacier Only	5mm	9 Sheets	0.93 m ²	10.44 kg
		(A) Antislip	Glacier Only	5mm	9 Sheets	0.93 m ²	10.44 kg
4	320x320mm (25x25mm) Ref. 320 Square Mosaic	(S) Smooth	Ice, Blue & Navy Only	5mm	9 Sheets	0.93 m ²	10.96 kg
		(A) Antislip	Ice, Blue & Navy Only	5mm	9 Sheets	0.93 m ²	10.96 kg

Note: All sizes indicated are metric modular. All dimensions are in millimetres. All sizes shown are nominal. For the most up-to-date availability information, please visit our website. All LRV results are from Johnson Tiles' internal test reports and are to be used for guidance only. LRV: Light Reflectance Value.



Swimming Pool Fittings

VI: Low Shade Variation

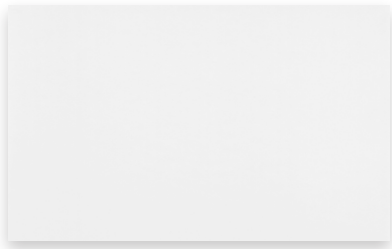

WHITE LRV: 74

(S) AP845N + (A) AP845A



AZURE LRV: 54

(S) AP841N + (A) AP841A



MARINE LRV: 10

(A) AP843A

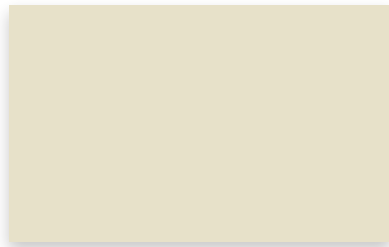

IVORY LRV: 54

(R) AP639N

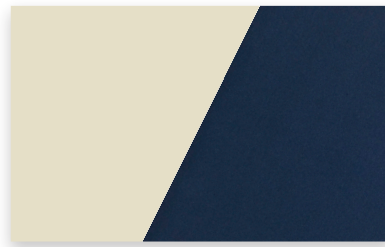

IVORY/MARINE

(R) AP639N



WHITE/MARINE

(A) AP845A



AZURE/MARINE

(A) AP841A

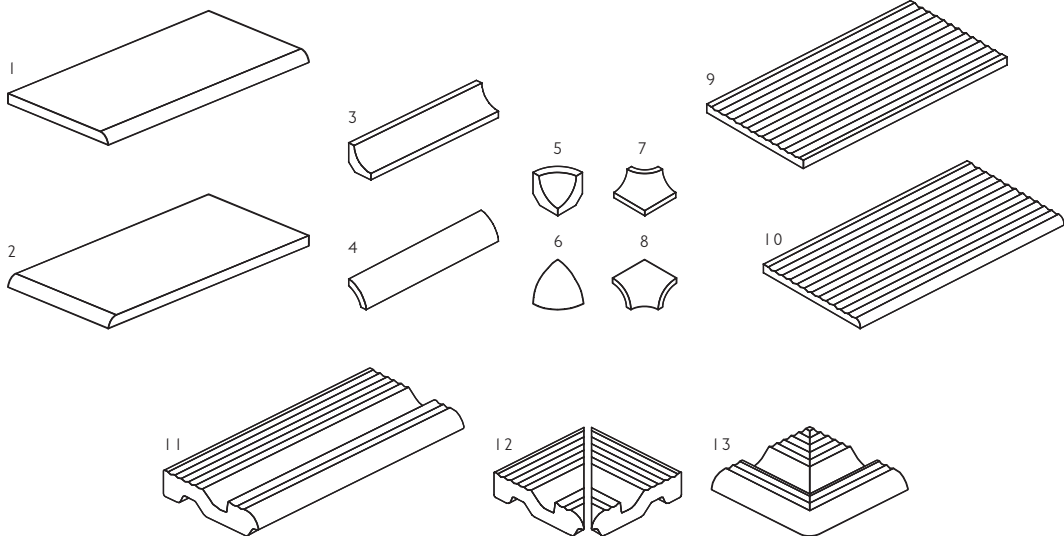

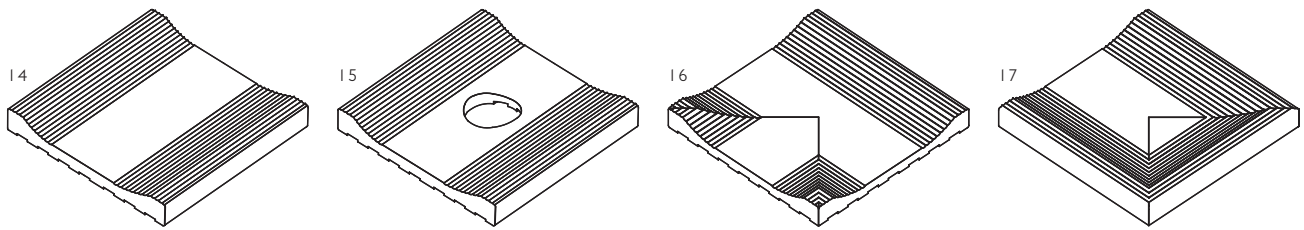

#	Size	Finish	Colour Availability	Thickness	Pieces/Box	Coverage/Box	Weight/Box
1	250x125mm Ref. 013 REL Tank Tile	(S) Smooth	White & Azure Only	8mm	20 Tiles	5.00 lm	10.80 kg
		(A) Antislip	White, Azure & Marine Only	8mm	20 Tiles	5.00 lm	10.80 kg
2	250x125mm Ref. 009 RES Tank Tile	(S) Smooth	White & Azure Only	8mm	20 Tiles	2.50 lm	9.00 kg
		(A) Antislip	White & Azure Only	8mm	20 Tiles	2.50 lm	9.00 kg
3	250x46mm Ref. 112 Int. Bead	(S) Smooth	White & Azure Only	8mm	18 Tiles	4.50 lm	8.10 kg
4	250x46mm Ref. 138 Ext. Bead	(S) Smooth	White & Azure Only	8mm	26 Tiles	6.50 lm	8.58 kg
		(A) Antislip	White, Azure & Marine Only	8mm	26 Tiles	6.50 lm	8.10 kg
5	46x46mm Ref. 114 Int. Bead Corner	(S) Smooth	White & Azure Only	8mm	34 Tiles	-	3.74 kg
6	46x46mm Ref. 115 Ext. Bead Corner	(S) Smooth	White & Azure Only	8mm	70 Tiles	-	7.70 kg
		(A) Antislip	White, Azure & Marine Only	8mm	70 Tiles	-	7.70 kg
7	46x46mm Ref. 116 Int. Bead Corner	(S) Smooth	White & Azure Only	8mm	30 Tiles	-	3.30 kg
8	46x46mm Ref. 117 Ext. Bead Corner	(S) Smooth	White & Azure Only	8mm	30 Tiles	-	3.30 kg
		(A) Antislip	White, Azure & Marine Only	8mm	30 Tiles	-	3.30 kg
9	250x125mm Ref. 001 Ribbed	(A) Antislip	White, Azure, Marine & Ivory Only	8mm	42 Tiles	1.32 m ²	21.84 kg
10	250x125mm Ref. 003 Ribbed REL	(A) Antislip	White, Azure, Marine & Ivory Only	8mm	18 Tiles	4.50 lm	11.16 kg
11	250x125mm Ref. 007 Fingergrip	(R) Ribbed	Ivory/Marine Only	25mm	7 Tiles	1.75 lm	8.12 kg
		(A) Antislip	White/Marine & Azure/Marine Only	25mm	7 Tiles	1.75 lm	8.12 kg
12	125x125mm Ref. 088 Fingergrip Internal Corner	(R) Ribbed	Ivory/Marine Only	25mm	8 Tiles	-	4.56 kg
		(A) Antislip	White/Marine & Azure/Marine Only	25mm	8 Tiles	-	4.56 kg
13	125x125mm Ref. 043 Fingergrip External Corner	(R) Ribbed	Ivory/Marine Only	25mm	9 Tiles	-	5.13 kg
		(A) Antislip	White/Marine & Azure/Marine Only	25mm	9 Tiles	-	5.13 kg
14	250x250mm Ref. 204 Shallow Channel	(A) Antislip	Ivory Only	23mm	6 Tiles	1.50 lm	14.00 kg
15	250x250mm Ref. 205 Shallow Channel Outlet	(A) Antislip	Ivory Only	23mm	6 Tiles	-	14.00 kg
16	250x250mm Ref. 206 Shallow Channel T-Junction	(A) Antislip	Ivory Only	23mm	6 Tiles	-	14.00 kg
17	250x250mm Ref. 207 Shallow Channel Stop-End	(A) Antislip	Ivory Only	23mm	6 Tiles	-	14.00 kg

Note: All sizes indicated are metric modular. All dimensions are in millimetres. All sizes shown are nominal. For the most up-to-date availability information, please visit our website. All LRV results are from Johnson Tiles' internal test reports and are to be used for guidance only. LRV: Light Reflectance Value.



Technical Data

Specification

Range	Size	Wall Suitability	Floor Suitability	Wet Barefoot	CSV	Material
Pools	All Sizes Shown (S)	Internal & External	-	-	VI	Glazed Porcelain [Bla]
Pools	All Sizes Shown (A)	Internal & External	Internal Only	Yes	VI	Glazed Porcelain [Bla]
Pools	Mosaics (S)	Internal & External	-	-	VI	Glass
Pools	Mosaics (A)	Internal & External	Internal Only	Yes	VI	Glass

Floor Values

Finish	Colour	PTV (4S)	PTV (TRL)	R Value	Wet Ramp	PEI	Traffic
(S) Smooth	All Colours Shown	Dry 36+ Wet 0 - 24	-	-	-	-	Commercial
(A) Antislip	All Colours Shown	Dry 36+ Wet 36+	36+	-	C	-	Commercial

Note: Due to the manufacturing process of all floor tiles there may be small variations in slip resistance. Given this, please refer to our website for the most up-to-date information. The slip resistance properties of a surface can only be maintained with the implementation of an effective regular cleaning and maintenance regime. The frequency of cleaning should be determined by the property manager based on the potential level of surface contaminants. The need for an additional regular cleaning and maintenance regime is further heightened when tiles are used for external floor and wet barefoot applications. PTV: Pendulum Test Value.

Physical Properties

Test/Standard	Requirement	Test Result	Test/Standard	Requirement	Test Result
Length / Width EN ISO 10545 - 2	$\pm 0.6\% \leq \pm 2\text{mm}$	Pass	Modulus of Rupture EN ISO 10545 - 4	Min. 35N / mm ²	$\geq 35\text{N} / \text{mm}^2$
Thickness EN ISO 10545 - 2	$\pm 5\% \leq \pm 0.5\text{mm}$	Pass	Thermal Shock EN ISO 10545 - 9	Pass	Pass
Straightness of Side EN ISO 10545 - 2	$\pm 0.5\% \leq \pm 1.5\text{mm}$	Pass	Frost Resistance EN ISO 10545 - 12	Resistant	Resistant
Rectangularity EN ISO 10545 - 2	$\pm 0.5\% \leq \pm 2\text{mm}$	Pass	Chemical Resistance EN ISO 10545 - 13	Min. Class B	Class A
Surface Flatness EN ISO 10545 - 2	$\pm 0.5\% \leq \pm 2\text{mm}$	Pass	Stain Resistance EN ISO 10545 - 14	Min. Class 3	Pass
Water Absorption EN ISO 10545 - 3	$\leq 0.5\%$	$\leq 0.5\%$	Fire Rating	-	Class A I _{FL} Non Combustible
Weight / M ²	Product Weight May Vary				

Note: All products are classed as Bla - Glazed Porcelain. All products conform to BS EN 14411.

Sustainability Information

Range	Material	EPD	Recycled Content of the Tiles	Recycled Content of the Packaging	Recyclable Content of the Packaging
Pools	Glazed Porcelain [Bla]	Yes	Up to 60%	-	-

Important Information

During the manufacturing process of ceramic, vitrified and porcelain tiles, some variation in shade and pattern can occur. Before fixing any tiles; several boxes should be opened and their contents mixed to ensure that size, colour, shade and patterning are acceptable. The tiles shown are quality products and conform to the physical properties listed below.

- All sizes shown are metric modular.
- For specific suitability and fit-for-purpose details please contact our technical helpline.
- Johnson Tiles cannot accept responsibility for any tiles that have been fixed.
- Every effort has been made to ensure the accuracy of the information given.
- Johnson Tiles reserves the right to change specifications and availability without prior notice.
- Nothing in these statements does or will affect the statutory rights of the consumer.

© Johnson Tiles, Johnson, Absolute and Material Lab are registered trademarks and together with Kerastar and product names are the trademarks of H&R Johnson Tiles Limited and licensed to Norcros Group (Holdings) Limited trading as Johnson Tiles. © 2021 Johnson Tiles. All rights reserved.



For more information about Pools or
any of our other product ranges simply visit
www.johnson-tiles.com |      

Where To Find Us

Johnson Tiles

Harewood Street,
Tunstall,
Stoke on Trent,
Staffordshire,
ST6 5JZ

Tel: +44 (0)1782 575 575
Fax: +44 (0)1782 577 377
Email: info@johnson-tiles.com

Samples Enquiries

Tel: +44 (0)1782 524 043
Fax: +44 (0)1782 577 379
Email: samples@johnson-tiles.com

Technical Helpline

Tel: +44 (0)1782 524 111
Fax: +44 (0)1782 577 379
Email: techadvice@johnson-tiles.com

JOHNSON • TILES 
MADE IN THE UK SINCE 1901